



# Newform Energy offers the 3kW-23kW **Janfire NH Biomass Burner** and **Janfire Pellets Boiler**



Effective automatic cleaning of the burning chamber.



Easy to use control panel

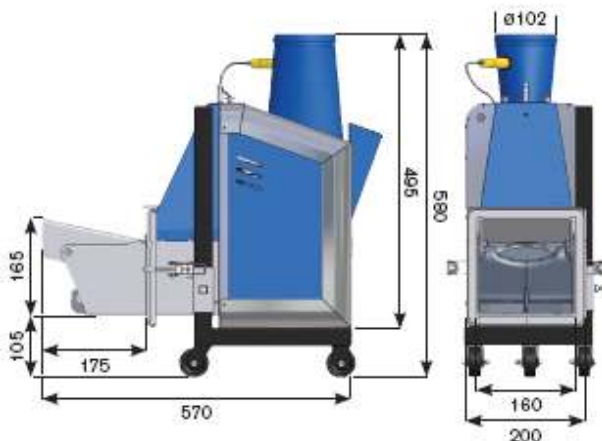

## Passivehouse Solutions Ltd

Ty Kama, Clos Yr Afon,  
Kidwelly, SA17 4TJ  
Tel: +44 (0)560 1122330  
Fax: +44 (0)560 1122331  
[www.passivehouse.co.uk](http://www.passivehouse.co.uk)  
[info@passivehouse.co.uk](mailto:info@passivehouse.co.uk)

## Pellets Burner for everyone – maintenance free

The Janfire NH pellets burner has, thanks to our patented new technique, the least maintenance time of any pellets burner on the market. The burner is completely automated and self-cleaning. It can run for 6 months without service or control (if fitted to a Janfire Pellet Boiler). When mounting onto a regular boiler the period between ash removals depends on the size of the ash container. The patented moving base of the burning chamber scrapes away slag and waste material, feeding it into the boiler's firebox. The burner automatically cleans itself according to pre-programmed intervals. Quick cleaning and a fast restart make for effective hot water production.

## Functions:

- Automatic cleaning of the burning chamber.
- Easy to use touch-button control panel.
- Programmable for optimal performance.
- Same functions as with the flex-a.
- Automatic ignition.
- Long life ignition element.
- High burning efficiency with low exhaust can only be achieved by a steady flow of pellets.
- This is accomplished with the use of a small internal feeding auger.
- The auger feeds the correct amount of pellets from the burner's internal pellet container.
- The burning chamber is constructed in such a way that very little fuel can escape the burning zone without being completely spent.
- No unused pellets can spill over into the boiler.
- The burning chamber is constructed of heat durable stainless steel.
- The burner stands on wheels, which makes it easy to move when removing ash and cleaning.
- Easy quick locking catch - for easy cleaning.
- Horizontal burning

## Technical specifications:

- Self-cleaning burning chamber, motorised, 40 W
- Effect: max 20 kW
- Internal dosage motor: 14 W
- Fan: 7 W, revolution controlled
- Internal dosage storage: volume approx. 3 l
- Easy to use control panel.
- Choice of summer or winter modes.
- Frame on wheels.
- Automatic ignition: 1100 W
- Safety: Meets the requirements for the P Mark set by SP.
- Efficiency: Meets the requirements for the P Mark set by SP and highest European requirements. Total electricity used should not exceed €10-20.

## Newform Energy

9 Aspen Rd, Chartham Down,  
Canterbury, CT4 7TB  
Tel: +44 (0)1227 733550  
Fax: +44 (0)1227 738463  
[www.newformenergy.com](http://www.newformenergy.com)  
[info@newformenergy.com](mailto:info@newformenergy.com)



## Janfire Pellets Boiler

### Easy cleaning and maintenance!

The Janfire Pellets Boiler works in perfect balance with both new and older Janfire burners. The burner is connected to the boiler without any alterations to the boiler. Maintenance is brought to an absolute minimum with the optional automatic decarbonisation lever. The boiler can be fitted with an automatic ash remover. The ash storage is so large that a home with a normal oil consumption of 4m<sup>3</sup> need only empty the ash twice yearly. Ask your chimney sweep about ash removal if you do not wish to do it yourself.

### Technical specifications:

- Chimney connection: Top or back
- Convection section: Vertical tubes
- Decarbonisation lever: Can be placed either left or right side of boiler.
- Weight: 295 kg
- Water volume: 150 l
- Firebox/ash container volume: 120 l
- Hot water: High effective cam flange coil ø22 mm L=11 m
- Operational Thermostat: Adjustable intervals of up to 15°
- Flu gas thermometer: Inbuilt with digital display
- Shunt
- Draft limitation hatch
- Touch-button control panel

### Extras:

Shunt automation with pre-programmed time intervals  
Electrical cartridges 3, 6, 9 kW



CE

# Janfire

pellets heating

Newform Energy offers a comprehensive supply and installation service for Janfire biomass pellet heating systems. Contact us to discuss your project requirements.

### Passivehouse Solutions Ltd

Ty Kama, Clos Yr Afon,  
Kidwelly, SA17 4TJ  
Tel: +44 (0)560 1122330  
Fax: +44 (0)560 1122331  
[www.passivehouse.co.uk](http://www.passivehouse.co.uk)  
[info@passivehouse.co.uk](mailto:info@passivehouse.co.uk)

### Newform Energy

9 Aspen Rd, Chartham Down,  
Canterbury, CT4 7TB  
Tel: +44 (0)1227 733550  
Fax: +44 (0)1227 738463  
[www.newformenergy.com](http://www.newformenergy.com)  
[info@newformenergy.com](mailto:info@newformenergy.com)